

Shut-off/check valve

509



Combination valve for water heating.

Max pressure: 1.0 MPa
Max working temp: 90 °C

Design

Valve body made from DZR-brass, EN 12165 CW602N with combined shut-off and check valve.

The valve has two female connections G $\frac{1}{2}$ for fitting safety/vacuum or filling valves, and 2 pipe connections 15 mm or 22 mm with compression fittings.

Fitting / Installation

The arrow on the valve housing indicates the direction of the flow.

The connections with female thread G $\frac{1}{2}$ are designed for LK Armatur's system with o-ring seals. Other articles are fitted in the usual manner.

Compression fittings for fitting to copper or steel pipes. For fitting to a male thread connection, adapter

LK 373 15 x G $\frac{1}{2}$, art.no 189 8022 or

LK 373 22 x G $\frac{3}{4}$, art.no 189 8055 is used.

It is easier to fit the compression fitting if a lubricant is applied to the thread and bevel. Tighten first by hand and then with a box spanner. Number of turns to be tightened with a spanner: See the table on page 21. Soft pipes are to be fitted with a support sleeve.

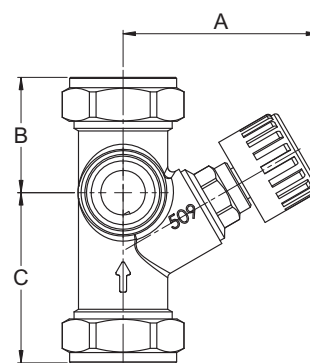

Operation and maintenance

The shut-off/check valve requires no maintenance. The installation should be checked regularly.

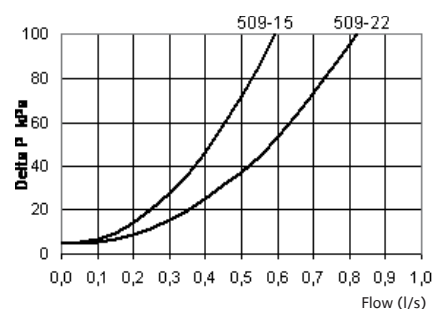

Article	Dimension	Art. no	Pack qty	A mm	B mm	C mm
509-15	15 mm	090131	1	55	35	43
509-22	22 mm	090029	1	55	35	51